

The following application note describes a PSpice model for the DEIC420 and IXDD415 gate driver ICs. This model was developed using Pspice Plugin version 9.2.3.268.

Referring to the schematic below, Vi is a pulse voltage source. TD, TR and TF should not be changed from their present settings. The IXDD415 is comprised of two of the models given in this document.

C1 and R1 allow for the internal power consumption as shown in Figures 6 and 7 of the DEIC420 data sheet. L1 and R2 model the internal impedance of the device. C2, L2, and R3 model internal strays of the DEIC420. R4 is necessary to insure that PSpice functions properly if the load is removed.

The load is comprised of C3, L3 and R5. C3 is the specified load capacitance. L3 and R5 represent the stray terms Equivalent Series Inductance (ESL) and Equivalent Series Resistance (ESR).

At the switching speed and operating frequency of the DEIC420 the inclusion of these stray terms is essential for proper device modeling. The average of the C1 Vprobe and the R1 Iprobe provide the consumed power and the C3 Vprobe provides a measurement of the output voltage.

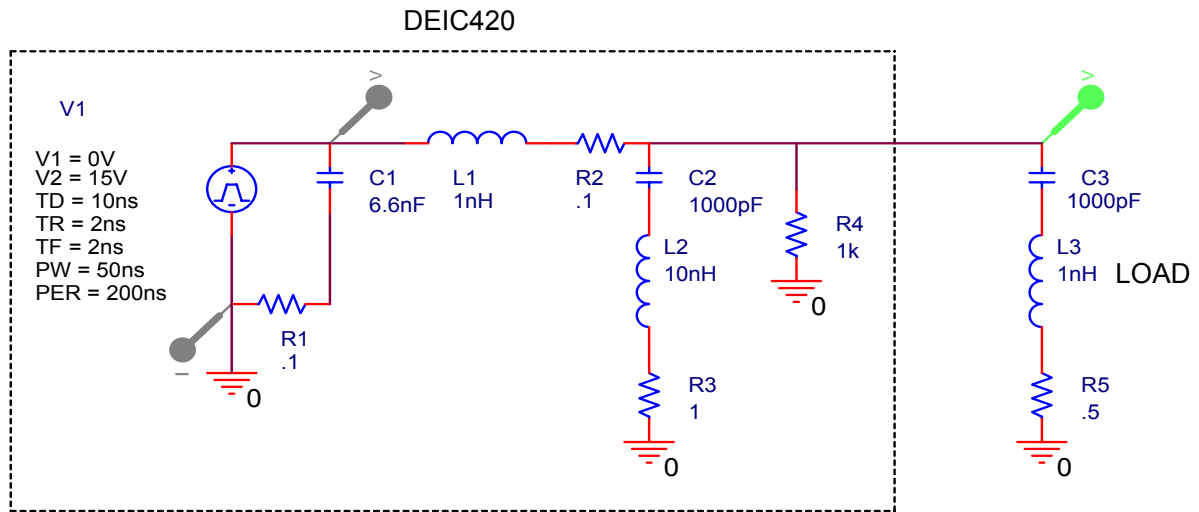

The following is the PSpice net list for the circuit of Figure 1.

Net List:

source IXD420

R_R3 0 N05435 Rbreak 1k

V_V1 N12321 0

+PULSE 0V 15V 5ns 2ns 2ns 50ns 200ns

R_R4 0 N139390 Rbreak .5

L_L1 N12321 N001311 Lbreak 1nH

C_C1 N16031 N12321 Cbreak 6.6nF

R_R2 N001311 N05435 Rbreak .1

L_L2 N139390 N137240 Lbreak 1nH

C_C2 N137240 N05435 Cbreak 1000pF

R_R1 0 N16031 Rbreak .1

Figure 2 is the spice output from the circuit of Figure 1. Comparison of Figure 2 below with Figures 11 and 12 in the data sheet for the DEIC420 show a reasonable correlation to times and wave shapes.

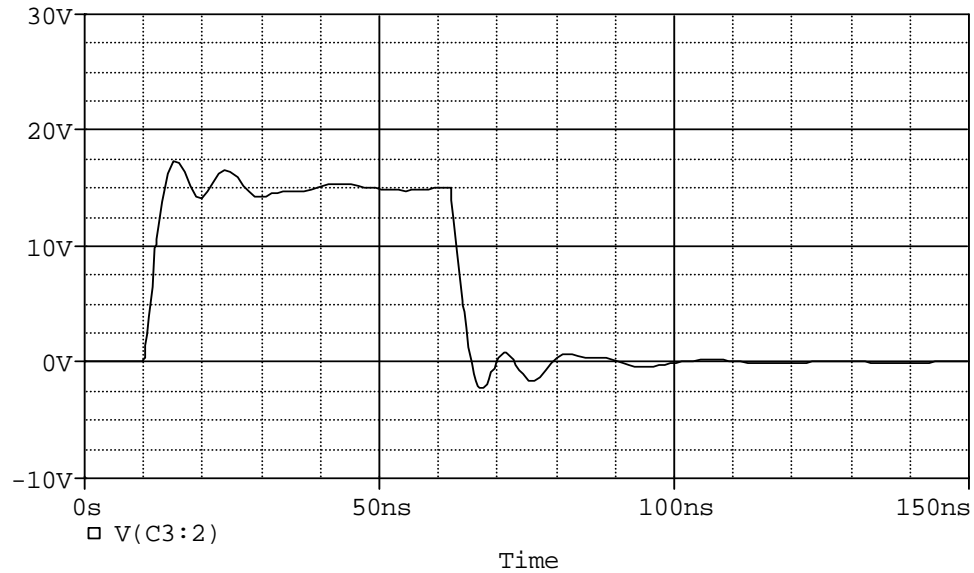

Figure 2 PSpice Output, 50ns Pulse Width, $C_L=1000\text{pF}$

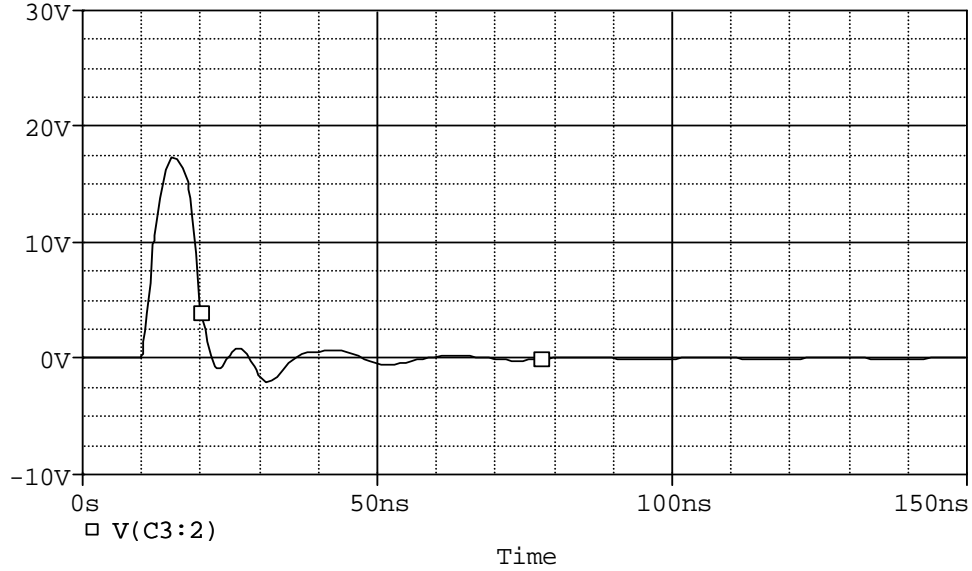

Figure 3 PSpice Output, Minimum Pulse Width, $C_L=1000\text{pF}$

Figure 3 illustrates the minimum pulse width. As speeds and frequencies move upward the inclusion of all strays becomes extremely important. Without these additional stray components the waveform reproduction becomes less and less like the actual device data.